

OBJECTIVE ANALYSIS OF LOUDSPEAKER POLAR RESPONSE

Michael Chamness

Eastern Acoustic Works, Inc., Whitinsville, MA USA

Reprinted from IOA, Windermere, November 1994

1. ABSTRACT

Conventional methods for calculating the beamwidth and Q of devices and systems appear questionable and incomplete when looking at measured polar data. Calculated beamwidth depends on the chosen method of normalizing the polar data and on a judgment of what response anomalies should be allowed inside and outside the area of coverage. Q is commonly referenced to a single measurement position on axis and it is therefore dependent upon device coverage angle. This obscures its usefulness as an indicator of the amount of excess and sometimes problematic sound radiated outside the intended coverage area.

Width of coverage, smoothness of response within the coverage angle, and amount of excess energy outside the coverage angle are all important to the sound quality and to the suitability of a loudspeaker for a particular application. A better way is needed to objectively evaluate and compare the coverage of devices and systems which overcomes these limitations. Proposed methods will be discussed.

2. INTRODUCTION

Engineers at EAW and other loudspeaker companies strive to design ideal loudspeaker systems. For directivity, what does this mean? Usually there is a requirement that the system provide even coverage over some listening area. It is equally important in many cases that very little sound is radiated to areas outside that listening area. Of course all of this needs to be achieved over as wide a frequency range as possible.

Within the listening area, there should be no favored direction. All of the audience should get the same good quality sound. The frequency response of the loudspeaker should be the same at all angles within the coverage angle. Outside of the coverage angle, ideally there should be no sound radiated from the speaker. This helps to keep strong reflections from entering the listening area and degrading the sound quality with delayed sound and comb filter effects. Sound radiated outside of the coverage angle is also wasted power.

If multiple speakers are used in an array, seamless coverage is required over the area covered by all of the loudspeakers. Somehow the individual speaker outputs must combine constructively to avoid lobing and interference effects. This could be achieved by a fictitious loudspeaker which had flat response over some coverage angle and then suddenly dropped to no output outside that area. This speaker could be splayed next to another at just the right angle to get seamless coverage between them.

Seamless coverage could also be achieved if the output of a speaker at the edge of its coverage area was exactly 6 dB down from its nominal level. The 2 neighboring speakers would then sum to provide seamless response between them. The roll off of response with angle would have to be such that perfect summing was achieved at all angles where the output of more than 1 speaker was contributing.

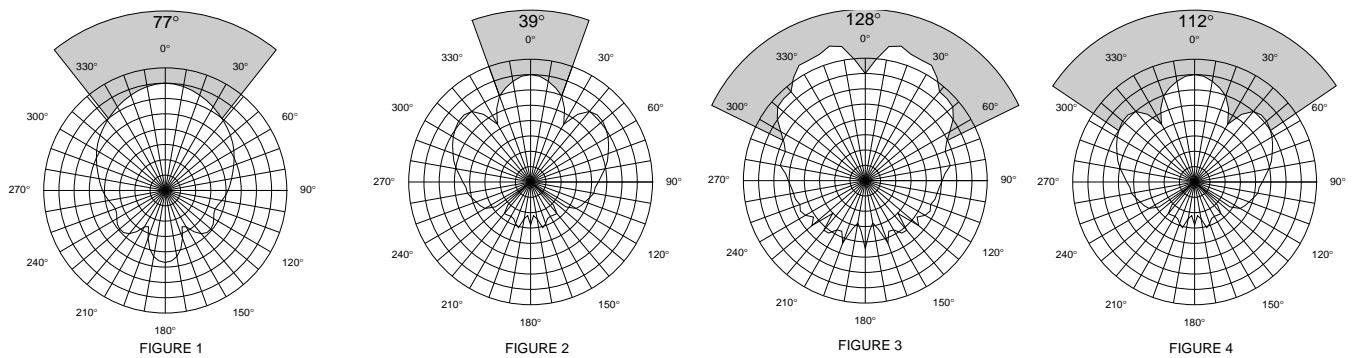

Unfortunately real loudspeakers fall short of these goals. So how do we best judge and compare the quality of coverage of real devices and systems for their intended application?

3. BEAMWIDTH OR COVERAGE ANGLE:

Davis has defined coverage angle as follows: “The coverage angle assigned to a given plane of radiation is that angle formed by the -6 dB points (referred to the on-axis reading) and the source center.” For ideal or well behaved systems the calculation is straightforward. One such device is shown in figure 1. It is a polar plot of a circular waveguide at the 3.15 kHz 1/3 octave.

But what if the loudspeaker has a response that falls with increasing angle to less than -6 dB and then rises above that level before ultimately falling off again? Using the definition of coverage angle above, the side lobes would be allowed outside the coverage angle. If this system was then chosen for an application based on it’s beamwidth curve, the results might be troublesome. If it were to be used near a boundary, the reflections from that boundary could seriously and unexpectedly degrade the sound quality. If it were to be used in an array, lobing and interference would be caused by the overlap of several devices. Figure 2 is a vertical polar plot of a popular small club PA speaker (4-speaker array) at the 2.5 kHz 1/3 octave which exhibits this problem.

Another problem arises with a system that has an on axis dip at some frequency or one whose highest output does not occur on axis. This is common in some “constant directivity” horns at some frequencies. In figure 3 we can see this problem in a 60 degree horn at 8 kHz. Finding the coverage angle referred to the on axis SPL gives a misleading result in this case. The calculated coverage angle will be wider than the true coverage angle of the device.

Considering a goal of even coverage over the intended listening area, minimal output beyond that area, and good arrayability, what is the best approach?

If a specification calls for a loudspeaker with a certain coverage angle, this is usually because output beyond that angle is a problem. Either strong boundary reflections or interference with another loudspeaker will result from a speaker with too wide a coverage angle. Therefore, strong sidelobes cannot be tolerated. To correctly calculate coverage angle in this case, one must find the angle where the output falls to less than -6 dB for the last time relative to the “reference level”. In figure 4 we see the difference in the calculated beamwidth at 2.5 kHz for the same speaker we saw in figure 2. Figure 5 shows the beamwidth curves for this device calculated for the first -6dB drop and the last -6 dB drop. The difference is significant.

With a response dip of greater than 6 dB allowed within the coverage angle, the response within the coverage area is now less than ideal. It is probably better to allow a dip at some angle within the listening area than to allow excessive output outside the coverage angle which might compromise output within the coverage angle over a wide area.

The calculated coverage angle will then still be dependent upon the method of normalization or the chosen reference level. A step in correcting the error from the on axis dip problem would be to find the angle of maximum output

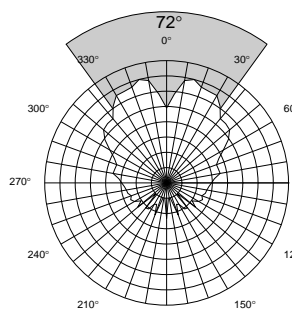
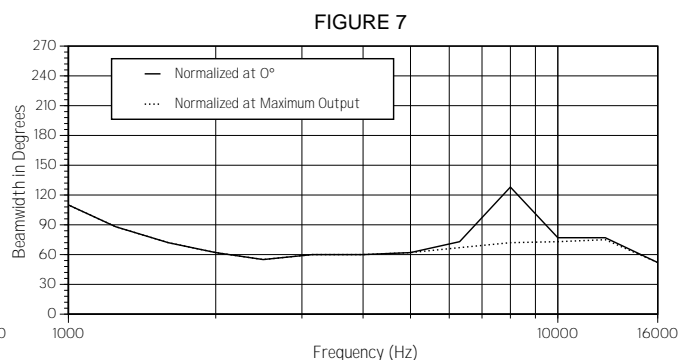
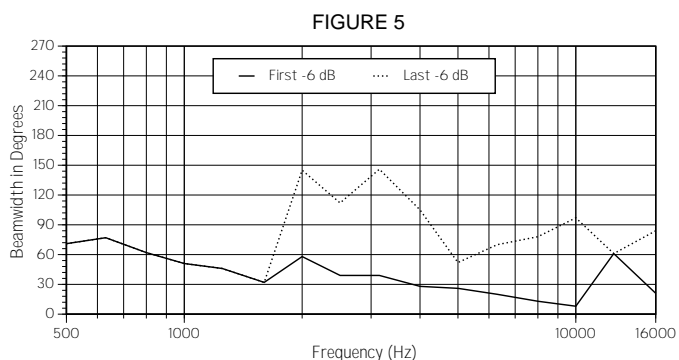

FIGURE 6

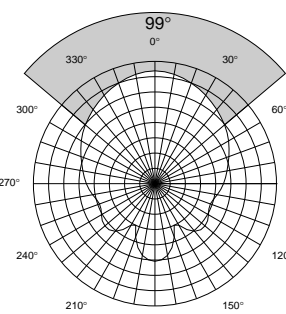

FIGURE 8

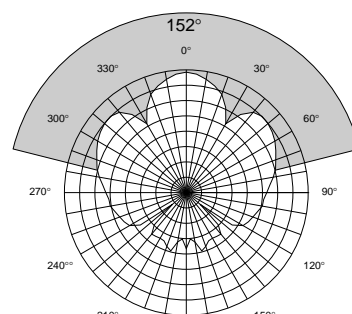

FIGURE 9

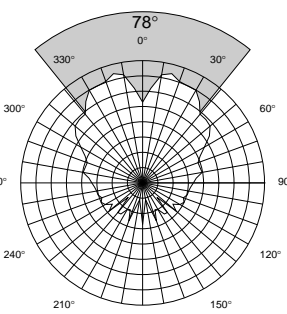

FIGURE 10

and use the level at that angle as the reference. Figure 6 shows our 60 degree horn at 8 kHz, normalized at the angle of maximum output. The beamwidth curves for this device using normalization at 0 degrees and at maximum output are compared in figure 7. The coverage angle is then the included angle outside of which the loudspeaker output is never greater than 6 dB less than the maximum level.

This improves the result, but choosing the maximum level as the reference is somewhat arbitrary. We are looking for the -6 dB angle with respect to the level over the area of coverage, not with respect to the level at any specific point.

Of course, normalizing polar responses is the same as applying an equalization curve to the loudspeaker. To examine the true coverage angle of the loudspeaker as a function of frequency, the proper EQ curve must be applied. It is important to note that when dealing with polar data in three dimensions the same normalization or EQ must be applied to the vertical and horizontal polars and all angles in between.

The smoothest possible response over the listening area will be achieved when the system power response over that listening area is smoothed. To apply this EQ curve, we normalize each frequency polar to 0 dB average power over the coverage angle. Then we can find the -6dB angles relative to that level.

This presents a problem since we cannot calculate power response over a coverage angle that we have not yet determined. We use an iterative solution. If we first normalize at the angle of maximum output, we can calculate a starting coverage angle. Then we can normalize to the power within that angle and go back and recalculate coverage angle. This can be repeated until the error is negligible. Figures 8, 9 & 10 are polar plots for our 3 previous examples normalized this way. In figure 11 we see the difference in the calculated beamwidth when normalized at max output and for 0 dB average power in the coverage angle for the 60 degree horn. The wider beamwidth result when normalizing for power is typical, since most loudspeakers are loudest directly on axis.

Since we are now allowing response dips of greater than 6 dB within the coverage angle it would be useful to know how consistent the response is within that angle. A suitable figure of merit might be to calculate the RMS error over the coverage angle and generate a response plot as a function of frequency. The error curves after normalizing for 0 dB average power are compared in figure 12 for our 3 examples.

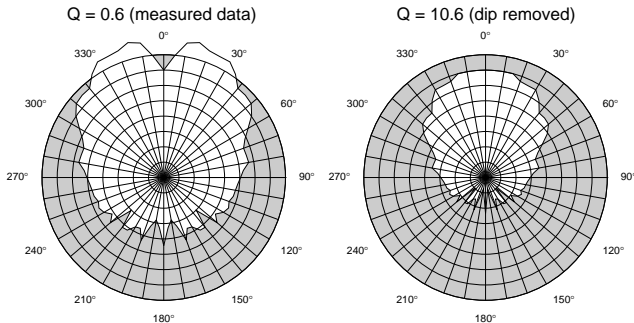
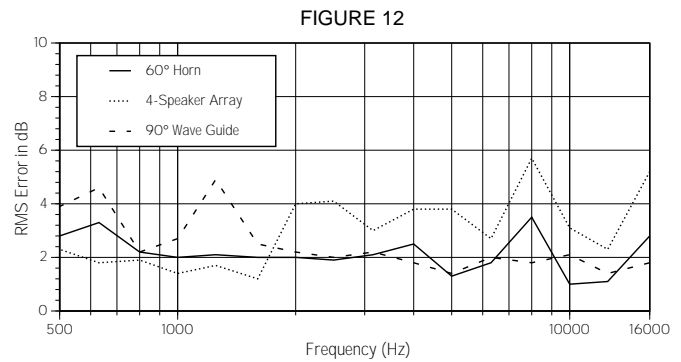
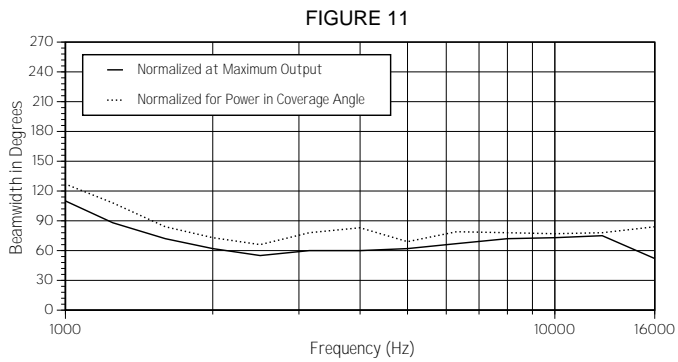

FIGURE 13

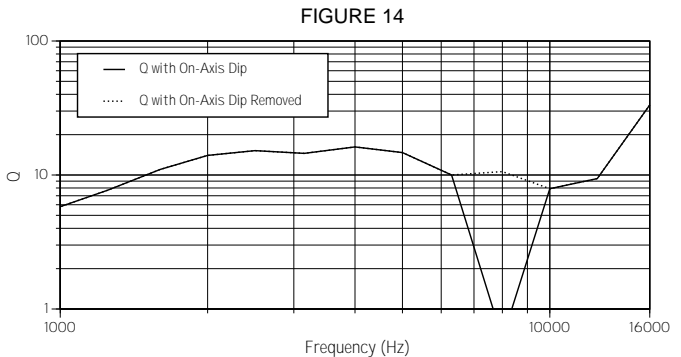

FIGURE 14

4. DIRECTIVITY FACTOR OR Q:

Once we have successfully computed the coverage angle of a device and determined how smooth its output is within that angle, we would still like to determine how much excess sound is radiated outside that angle. One indication of this is directivity factor.

The *New Audio Cyclopedia* states, “The directivity factor (Q) of a transducer used for sound emission is the ratio of sound pressure squared, at some fixed distance and specified direction, to the mean sound pressure squared at the same distance averaged over all directions from the transducer.”

When measuring real loudspeakers, this definition can give misleading results. Unless the output is maximum at the center axis of the main direction of the loudspeaker, the calculated Q will not be correct. As we discussed when calculating coverage angle, we run into problems if an on axis dip exists. We could try to correct this problem by averaging a few measurement points about the main axis, but depending on the width and depth of the response dip we may or may not improve the result. In figure 13 we see the calculated Q for our horn at 8 kHz with the on axis dip, compared to the result with the dip removed. Figure 14 compares the Q curves for the 2 cases.

There is no reason to favor one measurement point in the center of the direction of primary radiation. We want to know how good a job the loudspeaker is doing of providing even coverage over some specified angle, and as little output as possible outside that area. To compare the effectiveness of one loudspeaker over another in this regard, we should calculate how much sound is radiated in the coverage area compared to how much appears outside this area. It would be additionally useful if the result were independent of coverage angle. A given number then would indicate the same “sharpness of rolloff” outside the coverage angle for any device.

We could start by modifying the definition of Q to be “the ratio of the mean sound pressure squared averaged over the coverage angle, at some fixed distance and specified direction, to the mean sound pressure squared at the same distance averaged over all directions from the transducer.” This gives us a better indication of the directivity of the loudspeaker and solves the on axis null problem. Figures 15, 16 & 17 show Q as a function of frequency compared to our new “Q” which we might call Q(beam) for our 60 degree horn, 80 degree waveguide and 4 speaker array respectively.

FIGURE 15

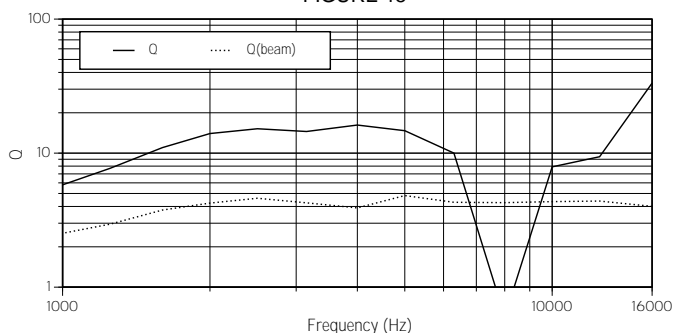

FIGURE 16

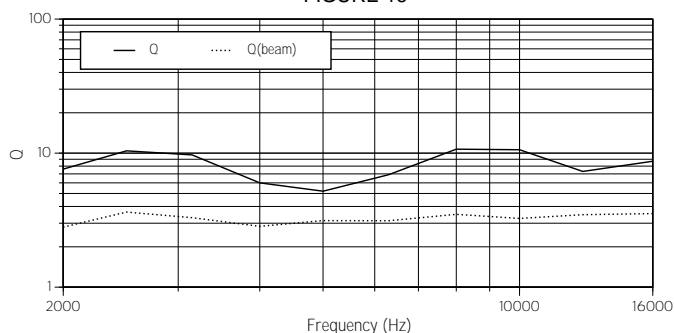

FIGURE 17

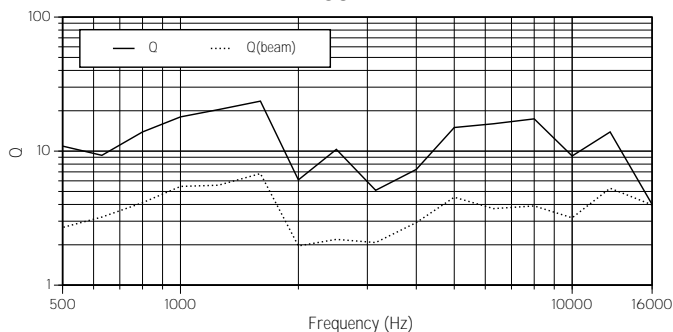
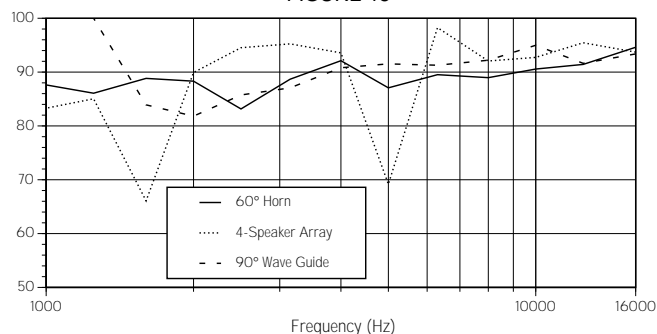

FIGURE 18



But the result is still dependent on coverage angle. To remedy this, we could compare the result to that of an ideal device. If we divide calculated $Q(\text{beam})$ by ideal and multiply by 100% we will have the desired result. Davis has suggested this as a loudspeaker figure of merit but using the conventional definition of Q .

To do this we need to define what an ideal device is. For our purpose, it could be defined as a device having perfectly flat response in the coverage angle, and no output beyond that so as to combine properly with an adjacent device. Figure 18 shows the results for our three examples.

5. CONCLUSION

The use of conventional definitions of directivity factor and coverage angle can result in errors in Q and beamwidth calculations for devices that are non-ideal. If we consider our goals to be consistent response everywhere within the coverage angle, and no output beyond that area, we can redefine our figures of merit to avoid these errors and more correctly represent the coverage angle and directionality of the loudspeaker. Additional figures of merit can then be used to judge the quality of coverage within the coverage angle, and to compare the amounts of excess sound radiated outside the coverage angle for devices of differing beamwidths.

6. REFERENCES

Davis & Davis, "Sound System Engineering", Howard W. Sams, Carmel Indiana, 1987

John Borwick, "Loudspeaker & Headphone Handbook", Butterworth & Co., London, 1988

Leo L. Beranek, "Acoustics", McGraw Hill, New York, 1954

Glen Ballou, "Handbook For Sound Engineers - The New Audio Cyclopedia", Howard W. Sams, Indianapolis, 1987