

Key Features:

- ▶ **High Technology Transducers**
355 mm (14 in) ultra-low distortion neodymium woofers with unique gap topology, 38 mm (1.5 in) exit, 100 mm (4 in) diaphragm neodymium compression driver.
- ▶ **Integrally Designed for Active Control**
For use with either our digital or analog controller that fully optimizes system performance.
- ▶ **Controlled Coverage**
Uniform horizontal coverage provides correct imaging, consistent sound at all console positions.
- ▶ **Versatile Mounting**
Soffit (Fits 813 installations), or free standing operation. Horizontal configuration available for Center or Installations with limited vertical clearance.

JBL's commitment to providing audio professionals the best tools for their work continues with the DMS-1 Studio Monitor System. To accomplish this, an overall view of the complete system design guided the engineers to interface control electronics with a well thought out integration of specialized components. The DMS-1 monitor features the world's first neodymium low-frequency transducer, a neodymium high frequency transducer with a unique diaphragm material, and a very low distortion constant directivity horn. To fully optimize system performance a supplied controller provides frequency division, equalization, and signal alignment. The result is a monitor capable of extremely high SPL over a wide bandwidth, with low distortion. Very flat amplitude and linear phase response provide the highest degree of accuracy.



Specifications:

All monitor specifications are with required controller	
MONITOR:	
Frequency Response ¹ (±3 dB):	30 Hz - 20 kHz
Sensitivity:	95 dB (1 W, 1 m)
Maximum SPL:	130 dB (2 m)
Harmonic Distortion (< 10 kHz):	< 0.3%
Power Linearity:	< 1 dB Compression of SPL Output
Horizontal Dispersion Angle (> 400 Hz):	100° (+10, -20)
Phase Response (100 Hz to 20 kHz):	±10°
High Frequency Transducer:	2450 SL-A 38 mm (1.5 in) Compression driver, 8 Ω, 100 mm (4 in) voice coil, pure titanium diaphragm, neodymium magnet
Power Rating:	75 W AES, 1 kHz to 10 kHz, 300 W peak
Recommended H. F. Amplifier Power:	200 W @ 8 Ω
High Frequency Horn:	Optimized Aperture Flat-Front Bi-Radial [®] , die cast aluminum
Low Frequency Transducers:	1401nd 355 mm (14 in) Ultra linear, neodymium magnet motor, Vented Gap Cooling [™] , 8 Ω, 100 mm (4 in) voice coil
Power Rating:	400 W AES, 50 Hz to 500 Hz, 1600 W peak
Recommended L. F. Amplifier Power:	1000 W @ 8 Ω (each Transducer)
Connectors:	Three Pair Double Banana, Direct to each Transducer
Dimensions (H x W x D):	914.4 x 584.2 x 527.05 mm (36 x 23 x 20.75 in)
Net Weight:	50 kg (110 lb.)
Finish:	Black Paint with neoprene baffle treatment
ELECTRONICS: SMC24 / DSC280	
Frequency Response ² :	10Hz - 20kHz ±1dB/15Hz - 20kHz +1, -0.25dB
Configuration:	2 Channels; 2-way out
Inputs (Balanced):	2 Channels, Max level +20dBu, Pin 2+ DSC280 Digital option, AES/EBU
Outputs (Balanced):	4 Bands / 8 Bands, Max level 20 dBu, Pin 2+
Dynamic Range	>110 dB / >105 dB
Total Harmonic Distortion:	<.005% typical, 0.1% max / <.001%, 20 - 20kHz, @ +10 dBu
Nominal Gain:	0dB (Unity Gain)
Sampling Rate:	NA / 48 kHz
Input/Output Converters:	NA / 20 bit
Crossover Frequency:	1kHz
Dimensions:	44.5 x 483 x 292 mm (1.75 x 19 x 11.5 in)/ 89 x 483 x 357 mm (3.5 x 19 x 14 in)

¹Half Space measurement
²Equalization, infrasonic filters disabled

► DMS-1 Studio Monitor System

Components

The DMS-1 builds upon a solid foundation: more than 40 years of JBL transducer expertise and engineering. The 355 mm (14 in) low frequency transducer represents JBL's commitment to research. New technology includes a unique deep copper-sleeved gap low-distortion motor structure topology, coupled to Vented Gap Cooling (VGC™)¹, delivering accurate reproduction at high power levels with minimal power compression. Harmonic distortion is effectively minimized through the use of dual shorting rings. An aluminum ring stabilizes flux modulation to reduce second harmonics, and a copper ring centered in the voice coil gap virtually eliminates third harmonic distortion. To improve both waveform accuracy and dynamic linearity the motor and voice coil were carefully engineered. A 100 mm (4 in) diameter voice coil, 16 mm (0.6 in) long is positioned in a deep gap to provide accurate motion to excursion extremes.

An optimized Thermal Management System™ uses both forced air cooling (VGC™) and convection cooling to reduce power compression. This increases acoustic output, and linear dynamic range. Convection cooling is accomplished by encasing the black, neodymium magnet assembly in a diecast aluminum frame designed as an effective heatsink. Dynamic range is increased by as much as 6 dB over competitive transducers. A glass fiber/paper composite cone achieves a very high stiffness to weight ratio, without problems found with other composites.

A new 38 mm (1.5) diameter exit neodymium high frequency compression driver with Coherent Wave™ phasing plug and 100 mm (4 in) diameter titanium diaphragm delivers low distortion response to beyond 20 kHz. Designed to directly couple to the phasing plug exit, is an Optimized Aperture™ technology horn that eliminates the compression driver's transition tube and restricted diffraction slot in the horn. This significantly reduces distortion to below audible thresholds. Its 100° horizontal pattern matches the low frequency array from below 400 Hz to above 16 kHz.

Controllers



DSC280 Digital Controller and SMC24 Analog Controller

¹U.S. Patent #5,042,072

JBL continually engages in research related to product improvement. New materials, production methods and design refinements are introduced into existing products without notice as a routine expression of that philosophy. For this reason, any current JBL product may differ in some respect from its published description but will always equal or exceed the original design specifications unless otherwise stated.

DMS-1 DIMENSIONS

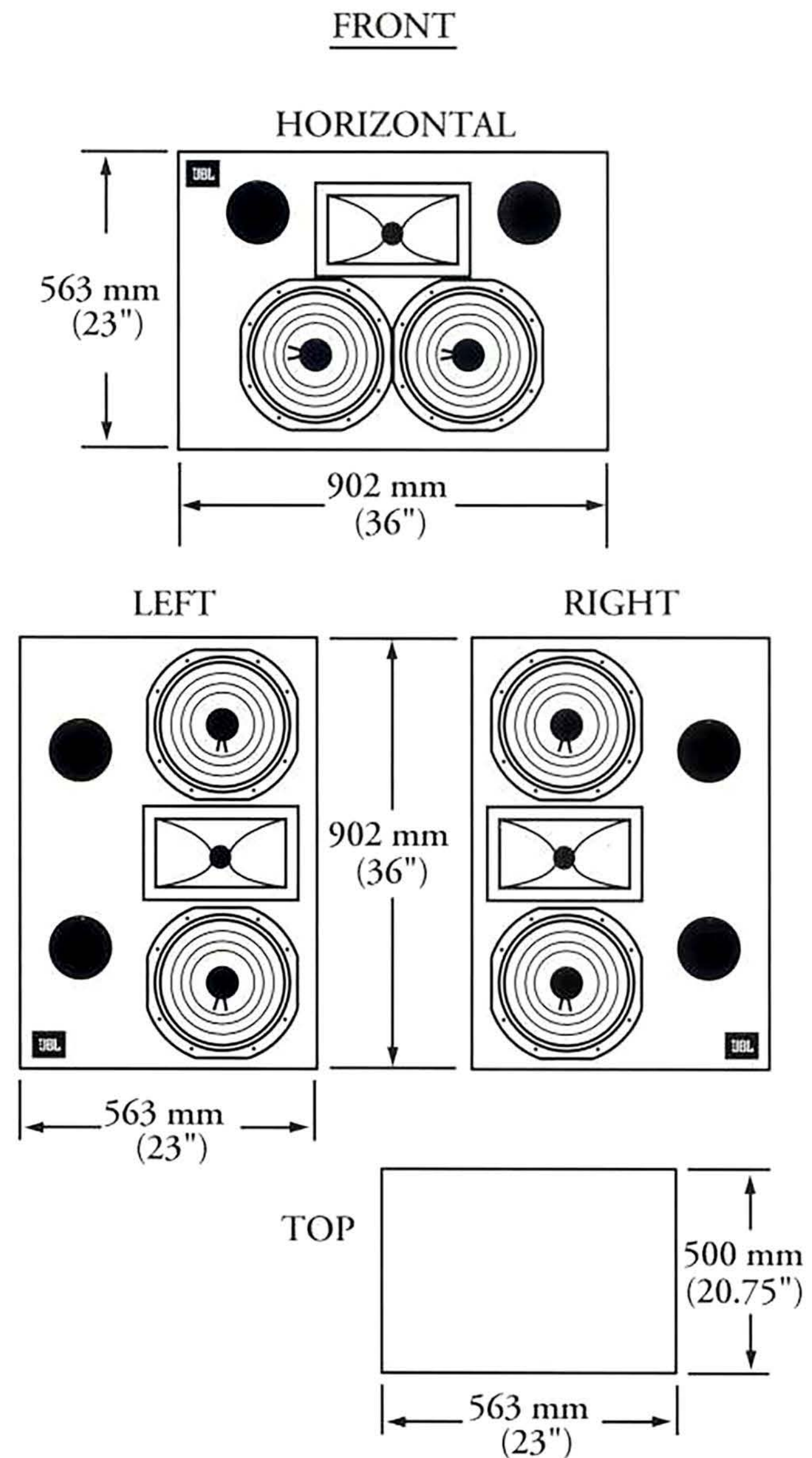

ALL DIMENSIONS ARE REF. ONLY
*Note: DIMENSIONS ARE IN MILLIMETERS (INCHES)



JBL Professional
8500 Balboa Boulevard, P.O. Box 2200
Northridge, California 91329 U.S.A.
H A Harman International Company

SS DMS-1
CRP 5M
10/96